

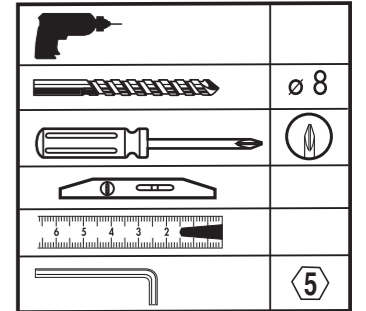

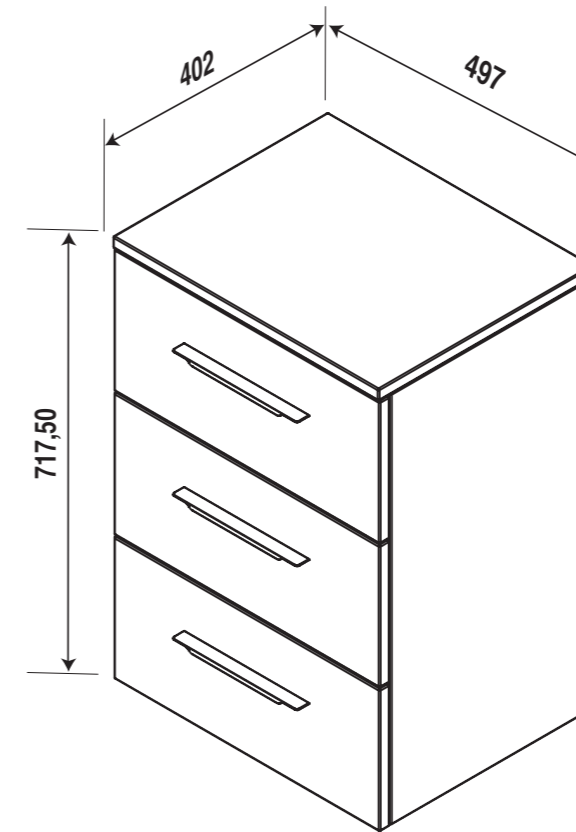

Meuble bas 3 tiroirs RIVOLI

7DD-3-6

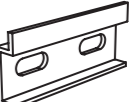

1		CHEVILLE 8 706014000035	X 4
2		VIS 5 X 50 TR 706003000127	X 4
3		PATIN 706002000087	X 2
4		BOU 663 706007000041	X 4
5		TAQ 830 706010000006	X 4

F	<ul style="list-style-type: none"> Mettre l'installation électrique hors tension avant de commencer la pose. Choisir l'emplacement du meuble afin que la prise électrique du meuble soit en dehors du volume de sécurité. Afin d'accroître la longévité de votre produit, nous vous recommandons de chauffer et de ventiler votre salle de bains pour éviter l'accumulation de vapeur et d'essuyer les projections d'eau. Pour une complète satisfaction, respectez les consignes d'installation et d'entretien. Leur non-respect peut entraîner la perte de la garantie
D	<ul style="list-style-type: none"> Vor Montagebeginn den Strom abstellen (Scherung ausschalten). Stellplatz auswählen und darauf achten, daß die E-Steckdose für das Möbelstück außerhalb des Sicherheitsbereiches liegt. Um eine lange Lebensdauer Ihrer Möbel sicherzustellen, empfehlen wir, das Badzimmer zu heizen und zu lüften, um hohe Luftfeuchtigkeit zu vermeiden. Wasserspritzer sollten trockengewischt werden. Damit das Möbelstück Sie vollstens zufriedenstellt, beachten Sie bitte die installations und Pflegevorschriften. Bei Nichteinhaltung erlischt der Garantie Anspruch.
GB	<ul style="list-style-type: none"> Isolate the electrical supply at the fuse box or consumer unit before attempting installation. The product must be positioned so that the electric socket is outside the electrical safety zone. To maximise the service life of your product, we recommend that your bathroom is properly heated and ventilated. This will prevent the build up of excess moisture and steam stagnation. Wipe with water splashes as they occur with clean cloth. For you complete satisfaction, carefully read the installation and maintenance instructions provided and retain for reference. Failure to follow the instruction may invalidate the product warranty.

N72005 MBLE BAS RIVOLI 50 3 TIROIRS - 30/02/2013

PARIS **DECOTEC**

1 FIXATION MURALE

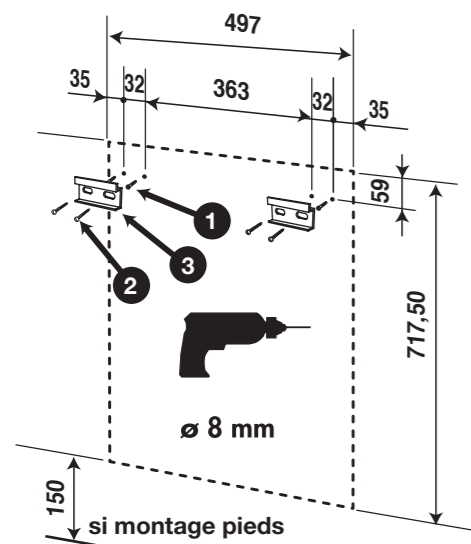

!

La fourniture des vis et chevilles n'engage pas DECOTEC, la bonne tenue du produit par le choix du matériel de fixation adapté à la nature du mur est de la seule responsabilité de l'installateur. Les sachets de quincaillerie fournis sont standards, certains composants ne sont donc pas utiles.

Die Lieferung der zur Installation notwendigen Schrauben und Dübel unterliegt nicht der Verantwortung der Firma Decotec. Die korrekte Auswahl der Befestigungselemente, abhängig vom Zustand und Tragkraft der Wand, wird durch den Installateur getroffen und fällt unter seine Verantwortung. Das im Lieferumfang enthaltene Montagezubehör ist eine Standardausführung. Es ist daher möglich, dass nicht alle Teile Verwendung finden.

The provision of screws and wall plugs does not render DECOTEC responsible for the stability of the installation. The choice of suitable fixings adapted to the nature of the wall on which the unit will be hung is the sole responsibility of the installer. There is a standard fixing kit for Decotec units. Therefore there will be some surplus items.

4 REMONTAGE DES TIROIRS

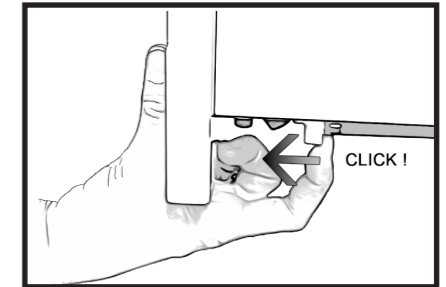
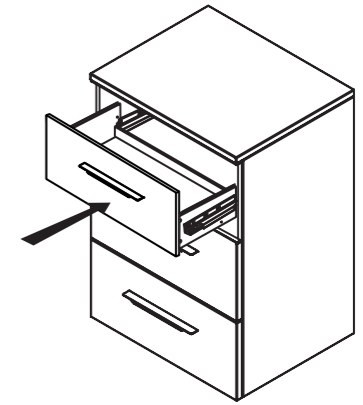
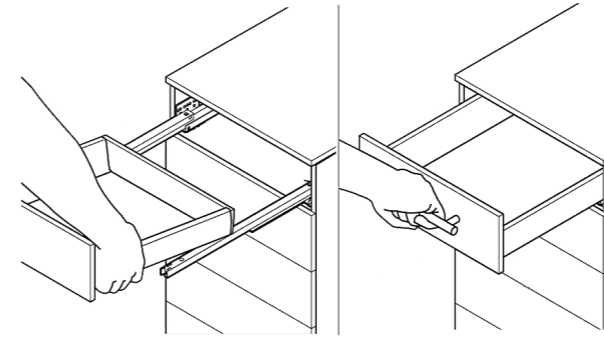

2 DÉMONTER LES TIROIRS

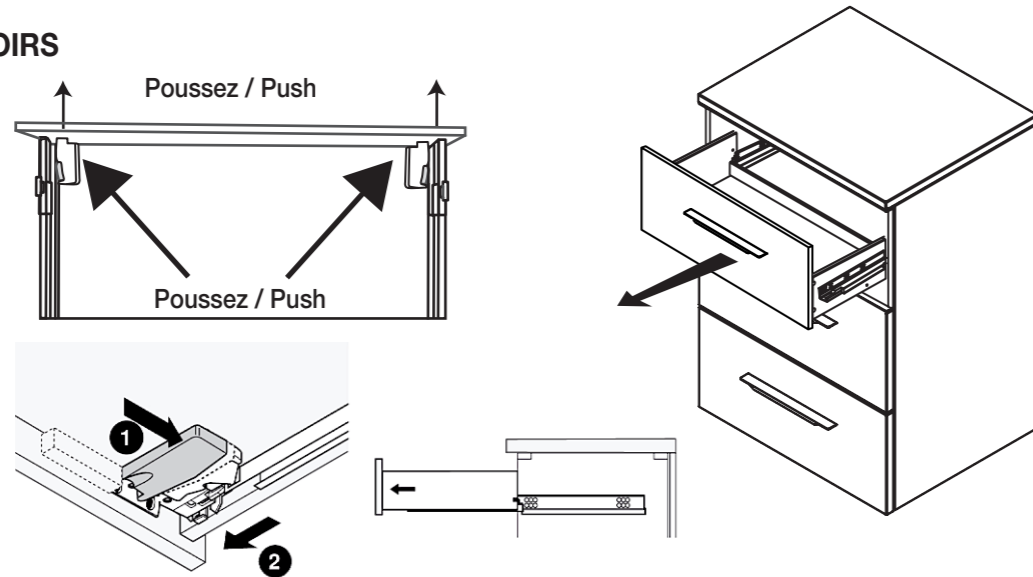

3 MISE EN PLACE AU MUR

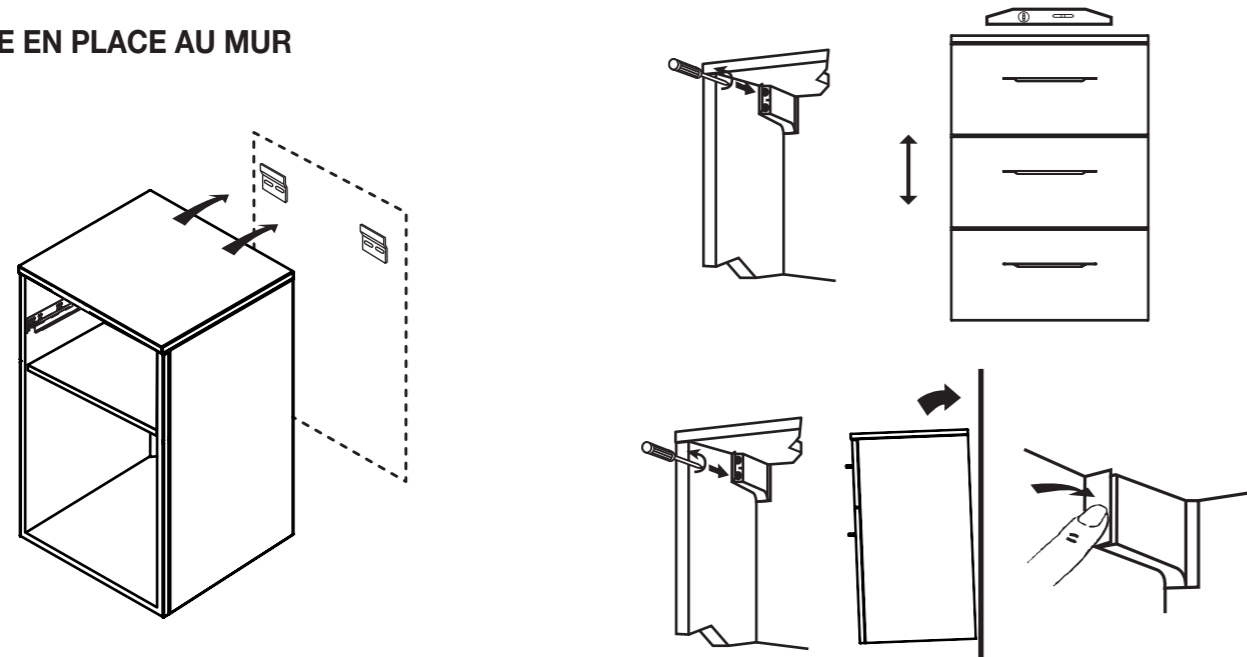

5 RÉGLAGE DES TIROIRS Réglage hauteur des tiroirs

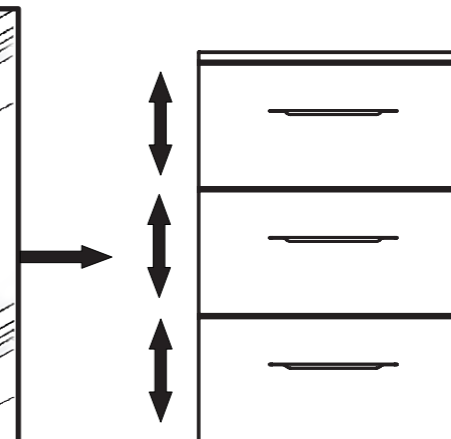
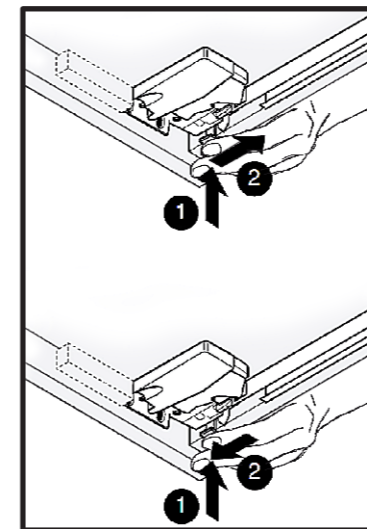

6 Réglage inclinaison des tiroirs

